



**Kobe**

**PD-6300~PD-6331**

Our Kobe fixtures are extremely thick metal rings joined into a concentric donut shape by an elaborate interior superstructure that both binds and centers their ultimate positioning. The effect is a simplistic...almost exotic... fixture with a contemporary edge that moves it into the realm of classic modernism. The harsh tone of the metal ring is offset by the soft glow of the acrylic lens. The Kobe frame allows for some wonderful lamping options. Plenty of room for CFL and LED lamps and chips. Acrylic lenses can be multiple colors as can the metal finishes. Be aware these are heavy lights...prepare!

**~Kobe Series~**

- Chandelier: CH-6300~CH-6311
- Pendant: PD-6300~PD-6331
- Ceiling Mount: CL-6300~CL-6308
- Wall Mount: SC-6300~SC-6311
- Bollard: BL-6300~BL-6311

**Mounting:** Lightsmith fixtures mount to standard 4" octagon electrical boxes unless otherwise specified. All hardware and canopies supplied.

**Listing and Warranty:** Lightsmith fixtures are Underwriters Laboratories listed and carry a standard three year warranty against defects in materials and labor beginning at date of shipment.



**Fixture Specifications**

<b>PD-63</b> <small>FIXTURE NUMBER (Example: PD-6300)</small>	~	<small>DIFFUSER (Example: BGA-ECH)</small>	~	<small>METAL FINISH (Example: ABB)</small>	~	<small>VOLTAGE  <input type="checkbox"/> (120V)  <input type="checkbox"/> (277V)  <input type="checkbox"/> (347V)         </small>	~	<small>STEM=S+Lgth (Example: S-96")          CHAIN=C+Lgth (Example: C-96")          NR=Not required       </small>	~	<small>OPTIONS (Example: DIM, REM)</small>	~	<small>MODIFICATIONS (Example: Custom Paint)          Use "Notes" Box At Top To Explain Modifications       </small>
--	---	--	---	--	---	--	---	--	---	--	---	--

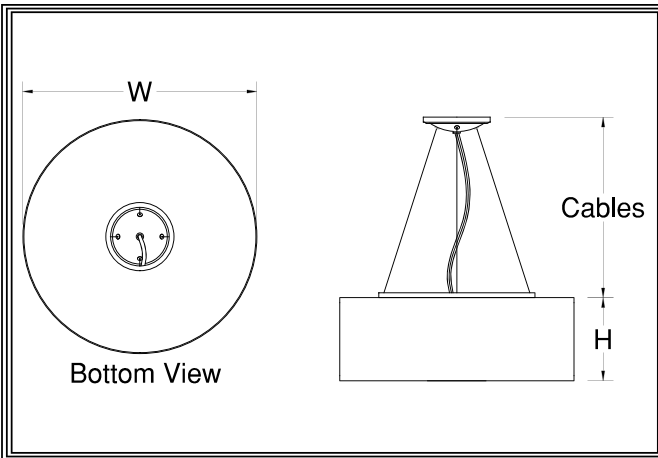

**PD-63** Job Type

Fixture Number Job Name

---

Job Name

---

Notes~Modifications

	Fixture Number	Dimensions	Lamping	Weight	Cables	Options
LED	<input type="checkbox"/> PD-6309	18w x 7h	4-13wCLED	35 lbs	3' Std	DALI,IEM,TPL,FUS**
	<input type="checkbox"/> PD-6310	24w x 9h	6-13wCLED	47 lbs	6' Std	L423,L623
	<input type="checkbox"/> PD-6311	30w x 11h	4-23wCLED	59 lbs	9' Std	L423,L623,L311
	<input type="checkbox"/> PD-6312	38w x 14h	4-38wCLED	71 lbs	9' Std	L623,L823,L611
	<input type="checkbox"/> PD-6313	48w x 18h	6-52wCLED	86 lbs	12' Std	L623,L823,L611
INCANDESCENT	<input type="checkbox"/> PD-6320	18w x 7h	3-100wA	31 lbs	3' Std	N250
	<input type="checkbox"/> PD-6300	24w x 9h	3-150wA	42 lbs	6' Std	N300
	<input type="checkbox"/> PD-6321	30w x 11h	6-100wA	55 lbs	9' Std	N300
	<input type="checkbox"/> PD-6301	38w x 14h	6-150wA	67 lbs	9' Std	N500
	<input type="checkbox"/> PD-6302	48w x 18h	12-150wA	82 lbs	12' Std	N500
FLUORESCENT	<input type="checkbox"/> PD-6330	18w x 7h	2-42wCFT	34 lbs	3' Std	DIM,IEM,TPL,FUS*
	<input type="checkbox"/> PD-6303	24w x 9h	4-42wCFT	46 lbs	6' Std	F242
	<input type="checkbox"/> PD-6331	30w x 11h	6-42wCFT	57 lbs	9' Std	F242
	<input type="checkbox"/> PD-6304	38w x 14h	8-42wCFT	69 lbs	9' Std	F442
	<input type="checkbox"/> PD-6305	48w x 18h	10-42wCFT	84 lbs	12' Std	F442

~Two Circuits Standard Wiring~

\*All Fluorescent Fixtures  
\*\*All LED Fixtures

DIFFUSER	<input type="checkbox"/> <b>BGA:</b> Beige Alabaster Acrylic	<input type="checkbox"/> <b>GRA:</b> Green Edge Acrylic	<input type="checkbox"/> <b>ECH:</b> Etched*
	<input type="checkbox"/> <b>NHA:</b> Natural Horn Acrylic	<input type="checkbox"/> <b>EGA:</b> Earth Green Acrylic	<i>*Etched option creates a matte, non-glossy finish on one side of the diffuser. (Example: WOA-ECH)</i>
	<input type="checkbox"/> <b>WHA:</b> White Alabaster Acrylic	<input type="checkbox"/> <b>DGA:</b> Deep Gold Acrylic	
	<input type="checkbox"/> <b>HNA:</b> Honey Alabaster Acrylic	<input type="checkbox"/> <b>SBA:</b> Sea Blue Acrylic	
	<input type="checkbox"/> <b>WOA:</b> White Opal Acrylic	<input type="checkbox"/> <b>PHA:</b> Purple Haze Acrylic	

	SOLID BRASS FINISHES	PAINTED METAL FINISHES	ALUMINUM FINISHES	STAINLESS STEEL FINISHES
METAL FINISH	<input type="checkbox"/> <b>ABB:</b> Antique Brass	<input type="checkbox"/> <b>DGP:</b> Dark Green	<input type="checkbox"/> <b>SAA:</b> Satin Aluminum	<input type="checkbox"/> <b>SSS:</b> Satin
	<input type="checkbox"/> <b>SBB:</b> Satin Brass	<input type="checkbox"/> <b>VGP:</b> Verde Green	<input type="checkbox"/> <b>SNA:</b> Satin Nickel	<input type="checkbox"/> <b>DSS:</b> Distressed
	<input type="checkbox"/> <b>PBB:</b> Polished Brass	<input type="checkbox"/> <b>CGP:</b> Charcoal Gray	<input type="checkbox"/> <b>PAA:</b> Polished Aluminum	<input type="checkbox"/> <b>PSS:</b> Polished
	<input type="checkbox"/> <b>ANB:</b> Antique Nickel	<input type="checkbox"/> <b>MBP:</b> Medium Bronze	<input type="checkbox"/> <b>BBA:</b> Burnished Bronze	<input type="checkbox"/> <b>HSS:</b> Hammered
	<input type="checkbox"/> <b>SNB:</b> Satin Nickel	<input type="checkbox"/> <b>SBP:</b> Satin Black	<input type="checkbox"/> <b>RNA:</b> Red Naval Bronze	<input type="checkbox"/>
	<input type="checkbox"/> <b>PNB:</b> Polished Nickel	<input type="checkbox"/> <b>DBP:</b> Dark Bronze	<input type="checkbox"/> <b>SGA:</b> Satin Gold	<input type="checkbox"/>
	<input type="checkbox"/> <b>AZB:</b> Antique Bronze	<input type="checkbox"/> <b>LBP:</b> Light Bronze	<input type="checkbox"/> <b>SBA:</b> Satin Bronze	<input type="checkbox"/>
	<input type="checkbox"/> <b>SZB:</b> Satin Bronze	<input type="checkbox"/> <b>MGP:</b> Medium Gold	<input type="checkbox"/> <b>ORA:</b> Oil Rubbed Bronze	<input type="checkbox"/>
	<input type="checkbox"/> <b>PZB:</b> Polished Bronze	<input type="checkbox"/> <b>SCP:</b> Sponged Copper	<input type="checkbox"/> <b>SCA:</b> Satin Copper	<input type="checkbox"/>
	<input type="checkbox"/> <b>CSB:</b> Custom Brass*	<input type="checkbox"/> <b>CSP:</b> Custom Paint*	<input type="checkbox"/> <b>CSA:</b> Custom Aluminum*	<input type="checkbox"/>
	<input type="checkbox"/>	<input type="checkbox"/>	<input type="checkbox"/>	<input type="checkbox"/>
	<input type="checkbox"/>	<input type="checkbox"/>	<input type="checkbox"/>	<input type="checkbox"/>
	<input type="checkbox"/>	<input type="checkbox"/>	<input type="checkbox"/>	<input type="checkbox"/>
	<input type="checkbox"/>	<input type="checkbox"/>	<input type="checkbox"/>	<input type="checkbox"/>

OPTIONS	<input type="checkbox"/> <b>N250:</b> 250wPar38 Downlight	<input type="checkbox"/> <b>L311:</b> 3-11wCLED Uplight	<input type="checkbox"/> <b>FUS:</b> Fusing
	<input type="checkbox"/> <b>N300:</b> 300wPar56 Downlight	<input type="checkbox"/> <b>L611:</b> 6-11wCLED Uplight	<input type="checkbox"/> <b>IEM:</b> Integral Emer.Ballast
	<input type="checkbox"/> <b>N500:</b> 500wPar56 Downlight	<input type="checkbox"/> <b>L423:</b> 4-23wCLED Downlight	<input type="checkbox"/> <b>DALI:</b> Dali dimming LED
	<input type="checkbox"/> <b>DIM:</b> Dimming Ballast	<input type="checkbox"/> <b>L623:</b> 6-23wCLED Downlight	<input type="checkbox"/> <b>F242:</b> 2-42wCFT Downlight
	<input type="checkbox"/> <b>TPL:</b> Top Lens	<input type="checkbox"/> <b>L823:</b> 8-23wCLED Downlight	<input type="checkbox"/> <b>F442:</b> 4-42wCFT Downlight
	<input type="checkbox"/>	<input type="checkbox"/>	<input type="checkbox"/>